

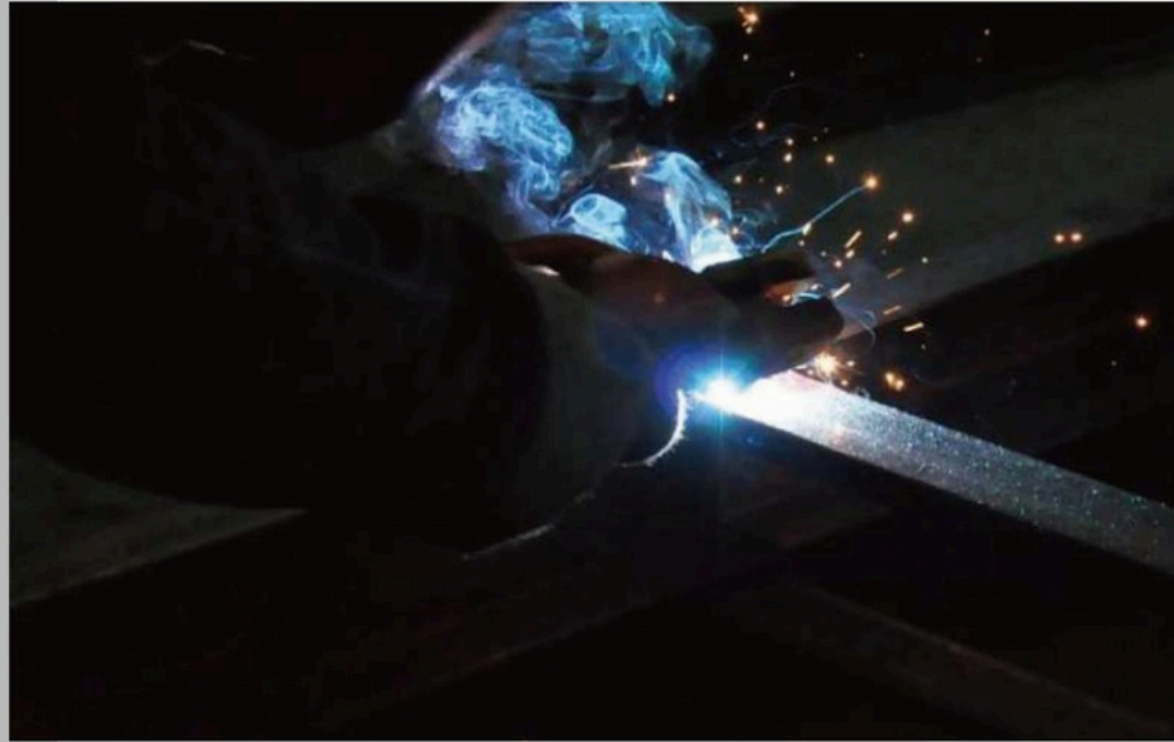

Content

| | |
|--------------------------------------|----|
| Performance Grilling Technology..... | 01 |
| Six Burners Series | 03 |
| Three & Four Burners Series | 09 |
| Built-in Series | 11 |
| Heavy Duty Series | 17 |
| Island Series | 25 |
| Outdoor Kitchen Series | 29 |
| Outdoor Kitchen Show Case | 35 |
| Steak & Pizza Maker Series | 51 |





Our engineers have a high academic qualifications and research experience. We obtain several technology patent regarding with gas appliances. We can manufacture the mold independently, this will help us develop the newproducts quickly and getting more advantages. With strict quality testing procedure, we can guarantee the safety of our products.

N&L

FURNITURE

Every N&L gas grill is built to provide unparalleled cooking performance delivering great barbecue flavor. You can sear steaks to perfection, rotisserie cook poultry and roasts. Every part of the cooking system is designed and engineered for giving you the ability to cook almost anything on your grill in any style. We devote to combine the comfort of an indoor kitchen range with all the benefits of being outside. N&L help create the ultimate backyard getaway.





Amazing Heat Retention

Made from high-grade stainless steel, these durable double-walled lid provide excellent heat retention and long lasting durability. Visible window and thermometer ensure even heat and heat retention for precise control.



Unmatched Performance

High quality and durable stainless steel burners and rear infrared burner are designed for heavy-duty "workhorse" grills. These cooking system provides superior heat distribution across the entire surface of the grill.



Perfect Temperature

Valve with 180 degree control knob give you infinite heat control, allowing you to set your grill to the perfect temperature for searing, roasting or slow cooking.



Stylish Illumination

Proper lighting creates drama, style and function. LED front panel lighting fetches eye-catching flair, while interior halogen lighting provides needed illumination for grilling regardless of the time of day.



Performance.

The Six Burners Series

The N&L Six burner series is perfect for large banquet events. These premium, heavy-duty grills are designed for performance, durability and exceptional results. Complete with interior lights, LED knobs, rear infrared burner, six #304 stainless steel burners, rotisserie set and flame thrower valves, you'll have the confidence these grilling machines are ready to sear the perfect steak.

#304 STAINLESS STEEL GRIDS

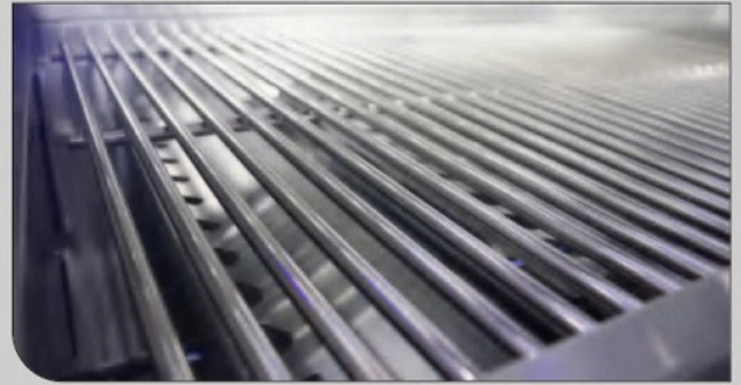

#304 STAINLESS STEEL BURNERS



STAINLESS STEEL FLAME TAMER

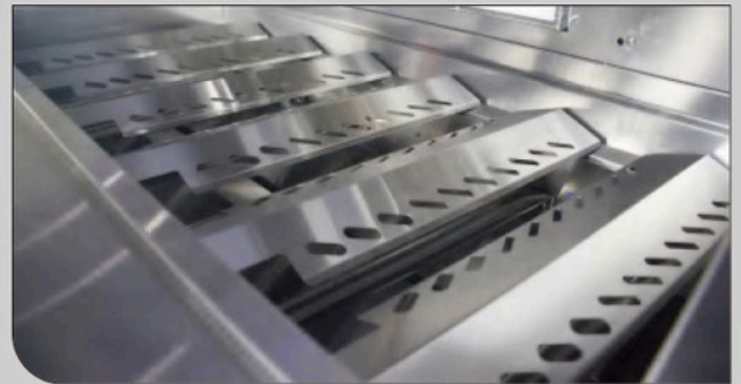

HEAT CONTROL COOK BOX

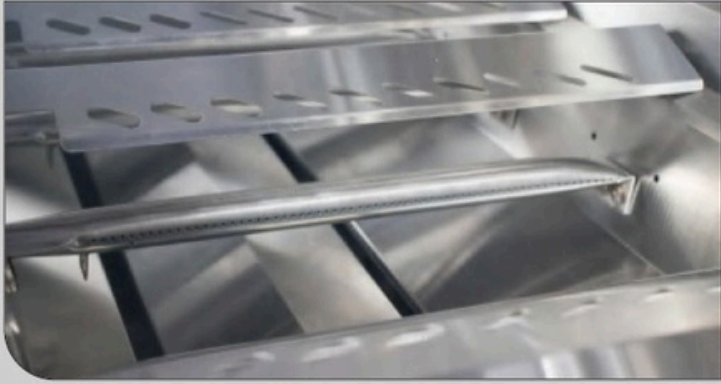

THERMOMETER



BEER OPENER

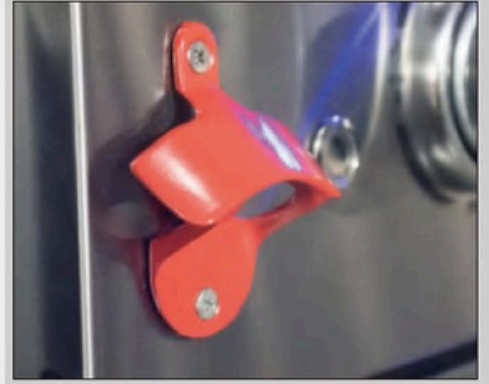

INFRARED REAR BURNERS

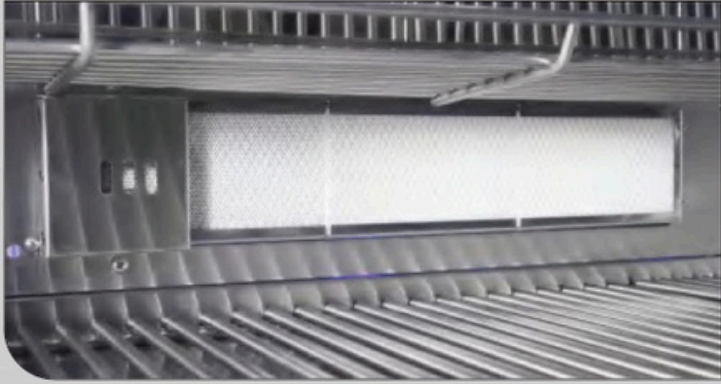

TEMPERED GLASS



DOUBLE-WALLED LID



KNOBS LED LIGHTS



BUILT-IN LIGHTS

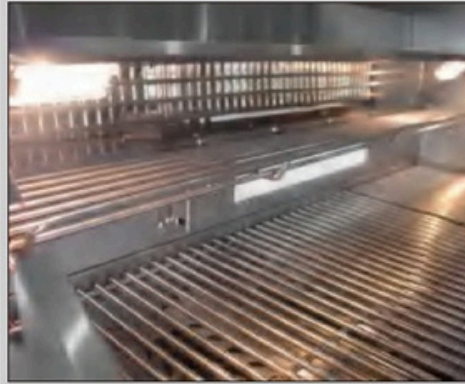

DRAWNS AND ACCESS DOOR

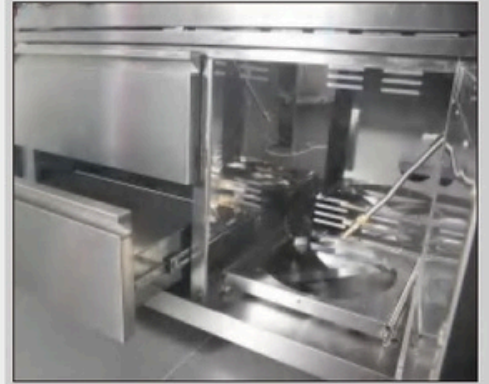

SIX BURNERS SERIES FEATURES

| | |
|------------------------|---|
| COOKING GRIDS | 8mm 304 stainless steel grids |
| HEAT CONTROL | Valves with 180° control |
| THERMOMETER | Thermometer available |
| WINDOW | tempered glass |
| IGNITION | Piezo ignition |
| SIDE SHELVES | Stainless steel side shelves |
| FAT TRAY | Stainless steel handles |
| CASTER | 4 caster wheels,2 with locking |
| BUILT-IN LIGHTS | Built-in halogen light and LED knob light |
| CONSTRUCTION | 430 stainless steel |
| MAIN BURNER | Stainless steel burner available |
| REAR BURNER | Infared burner available |
| ROTISSERIE | Rotisserie kits available |
| CABINET | Drawer and access door |



NL-B801 FEATURES

| | |
|-------------------------|--|
| COOKING AREA | 960*455mm |
| PRODUCT SIZE | 1100*580*1200mm |
| PACKAGE SIZE | 1190*690*1300mm |
| GROSS WEIGHT | 128kg |
| PROFORMANCE | 91100BTU/26.7kW |
| BURNERS | 3.7kW main burners,4.5kW rear burner |
| MOTOR OUTPUT | 13W(220 240V,AC50/60Hz), Max Load: 40 kg |
| LOADING QUANTITY | 13pcs/20GP 28pcs/40GP 56pcs/40HQ |

SIDE SHELVES UP



SIDE SHELVES FOLD DOWN



READY TO COMBINE



KITCHEN COMBINATION





STAINLESS STEEL ROTATABLE BASKET

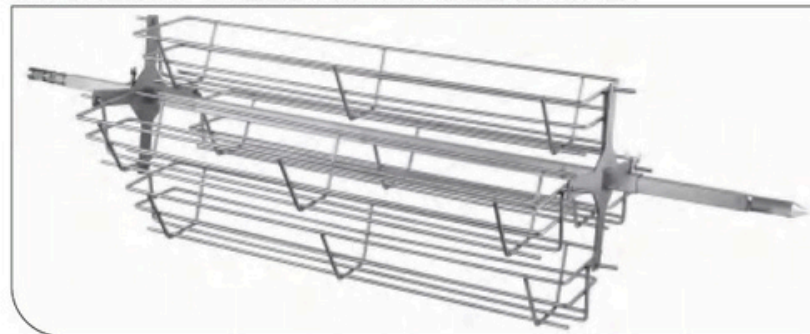

ELECTRIC MOTOR ROTISSERIE KIT



NL-B5 FEATURES

| | |
|-------------------------|--|
| COOKING AREA | 1300*600mm |
| PRODUCT SIZE | 2135*755*1150mm |
| PACKAGE SIZE | 1560*830*1300mm |
| GROSS WEIGHT | 152kg |
| PROFORMANCE | 91100BTU/26.7kW |
| BURNERS | 3.7kW main burners,4.5kW rear burner |
| MOTOR OUTPUT | 13W(220 240V,AC50/60Hz), Max Load: 40 kg |
| LOADING QUANTITY | 7pcs/20GP 15pcs/40GP 30pcs/40HQ |

HIGH PERFORMANCE AND HEAVY-DUTY GRILL





NL-B8 FEATURES

| | |
|-------------------------|--|
| COOKING AREA | 960*455mm |
| PRODUCT SIZE | 1468*600*1240mm |
| PACKAGE SIZE | 1560*690*1300mm |
| GROSS WEIGHT | 130kg |
| PROFORMANCE | 103000BTU/30.2kW |
| BURNERS | 3.7kW main burners, 4.5kW rear burner, 3.5kW side burner |
| MOTOR OUTPUT | 13W(220 240V, AC50/60Hz), Max Load: 40 kg |
| LOADING QUANTITY | 11pcs/20GP 24pcs/40GP 48pcs/40HQ |

3.5kW SIDE BURNER

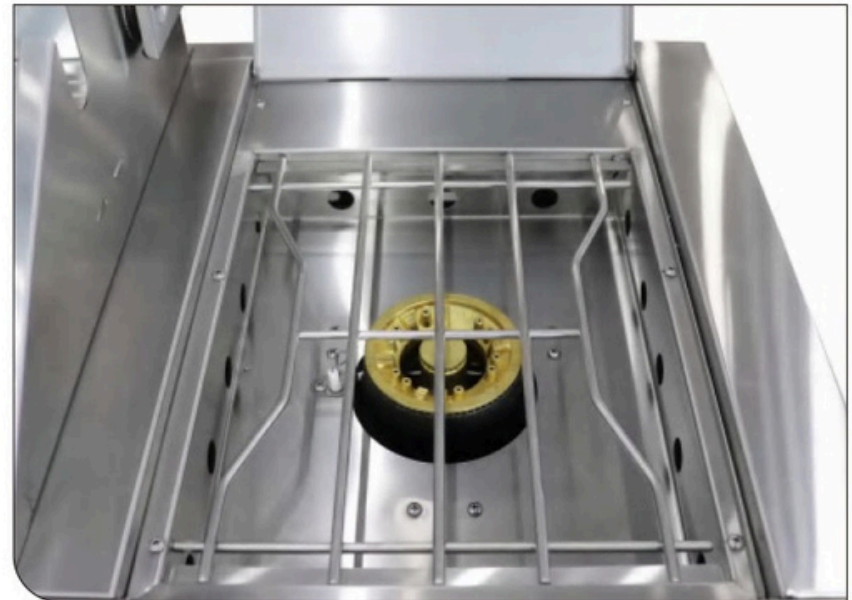

Compact.

Three & Four burners Series

The N & L has barbecues to fit any budget without sacrificing our exceptional quality. It's what sets the Three & Four burners series apart from its rivals. This modern-looking grill features a stainless steel cook box for great heat retention, powerful side ported dual-flame tube burners for even heat distribution, and valves for precise cooking control.



NL-B310 FEATURES

| | |
|-------------------------|---|
| COOKING AREA | 605*420mm |
| PRODUCT SIZE | 1176*560*1120mm |
| PACKAGE SIZE | 620*640*570mm |
| GROSS WEIGHT | 115kg |
| PERFORMANCE | 50000BTU/14.6kW |
| BURNERS | 3.7kW main burners, 3.5kW side burner |
| MOTOR OUTPUT | 13W(220 240V, AC50/60Hz), Max Load: 40 kg |
| LOADING QUANTITY | 107pcs/20GP 215pcs/40GP 215pcs/40HQ |





NL-B4S FEATURES

| | |
|-------------------------|--|
| COOKING AREA | 660*460mm |
| PRODUCT SIZE | 1170*580*900mm |
| PACKAGE SIZE | 1230*690*1350mm |
| GROSS WEIGHT | 115kg |
| PERFORMANCE | 78000BTU/22.8kW |
| BURNERS | 3.7kW main burners, 4.5kW rear, 3.5kW side |
| MOTOR OUTPUT | 13W(220 240V,AC50/60Hz), Max Load: 40 kg |
| LOADING QUANTITY | 13pcs/20GP 28pcs/40GP 28pcs/40HQ |





Builder.

The Built-in Series

The N&L Built-in Grill has been specially designed to accommodate all types of multi-family and commercial applications. Whether it is an apartment community, hotel, or country club, these environments get a great deal of extra use. This grill is the perfect option for any commercial application.



NL-B4-R BUILT-IN FEATURES

| | |
|-------------------------|---|
| COOKING AREA | 723*460mm |
| PRODUCT SIZE | 870*627*533mm |
| PACKAGE SIZE | 860*650*590mm |
| GROSS WEIGHT | 68kg |
| PERFORMANCE | 66000BTU/19.3kW |
| BURNERS | 3.7kW main burners, 4.5kW rear burner |
| MOTOR OUTPUT | 13W(220 240V, AC50/60Hz), Max Load: 40 kg |
| LOADING QUANTITY | 81pcs/20GP 162pcs/40GP 216pcs/40HQ |





NL-B4 BUILT-IN FEATURES

| | |
|-------------------------|---|
| COOKING AREA | 723*460mm |
| PRODUCT SIZE | 870*627*533mm |
| PACKAGE SIZE | 860*650*590mm |
| GROSS WEIGHT | 68kg |
| PERFORMANCE | 66000BTU/19.3kW |
| BURNERS | 3.7kW main burners, 4.5kW rear burner |
| MOTOR OUTPUT | 13W(220 240V, AC50/60Hz), Max Load: 40 kg |
| LOADING QUANTITY | 81pcs/20GP 162pcs/40GP 216pcs/40HQ |

MULTIFUNCTION GRILL



CONTROL PANEL LIGHTS



THERMOMETER AND DOUBLE-WALLED LID



COOK BOX BUILT-IN LIGHTS



#304 STAINLESS STEEL BURNERS

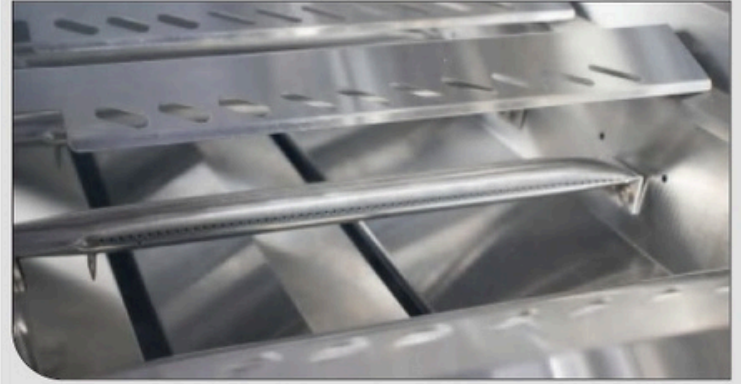

ROTISSERIE KIT



INFRARED REAR BURNERS

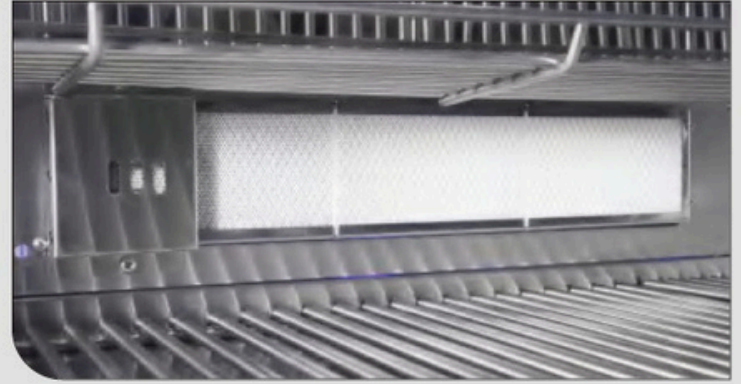

PIEZO IGNITOR AND BEER OPENER



#304 STAINLESS STEEL GRIDS

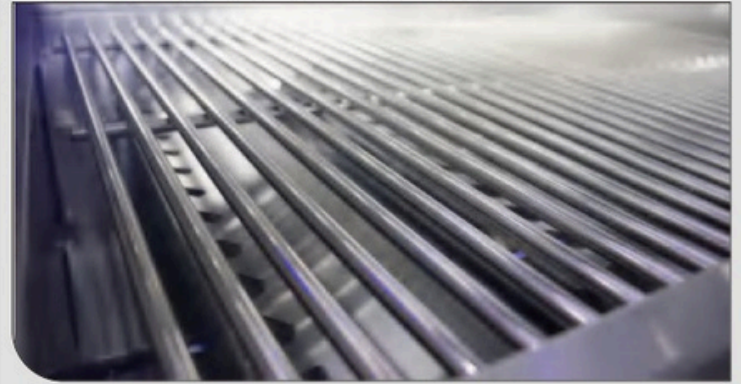



NL-B4-G BUILT-IN FEATURES

| | |
|-------------------------|--|
| COOKING AREA | 723*460mm |
| PRODUCT SIZE | 870*627*533mm |
| PACKAGE SIZE | 860*650*590mm |
| GROSS WEIGHT | 68kg |
| PERFORMANCE | 66000BTU/19.3kW |
| BURNERS | 3.7kW main burners,4.5kW rear burner |
| MOTOR OUTPUT | 13W(220 240V,AC50/60Hz), Max Load: 40 kg |
| LOADING QUANTITY | 81pcs/20GP 162pcs/40GP 216pcs/40HC |



COOK BOX BUILT-IN LIGHTS



#304 STAINLESS STEEL BURNERS

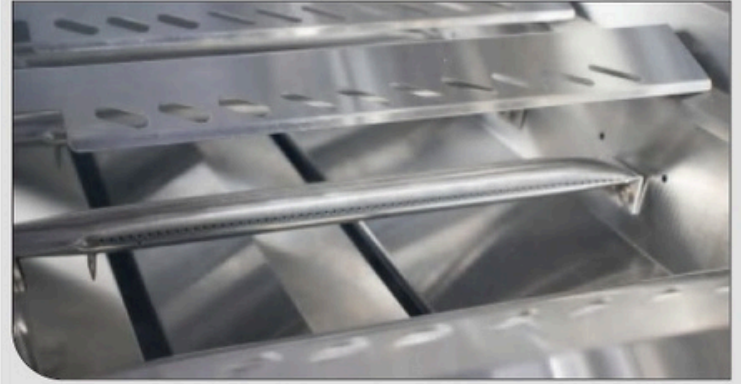

TEMPERED GLASS



INFRARED REAR BURNERS

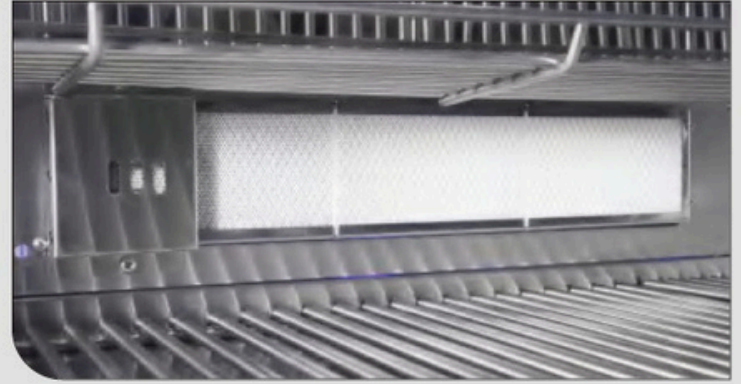

PIEZO IGNITOR AND BEER OPENER



#304 STAINLESS STEEL GRIDS

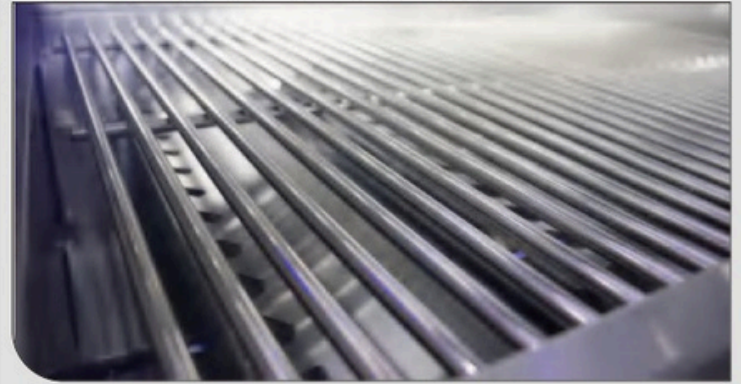



Feast.

The Heavy Duty Series

In the canon of cooking whole animals, few ways are more fun, more drool-enducing, more catchy to the eye than spit roasting. Roast whole lamb is a classic specialty of many cuisines. Whether its Superbowl Sunday or a lazy afternoon in the backyard, roasting a whole lamb on an outdoor grill is fun and relaxing. Use The N & L Heavy Duty Grills create this type of feast in your own backyard, and share a meal of flesh for your friends and family.



STAINLESS STEEL ROTATABLE BASKET



NL-B7 FEATURES

| | |
|-------------------------|--|
| COOKING AREA | 1460*650mm |
| PRODUCT SIZE | 1950*800*1170mm |
| PACKAGE SIZE | 1520*670*260mm; 1530*740*250mm |
| GROSS WEIGHT | 95kg |
| CHARCOAL TRAY | 720*450*80mm, Black enamel |
| BURNERS | 5.8kW infrared burners(Total 11.6kW) |
| MOTOR | 25W(220 240V,AC50/60Hz), Max Load: 60 kg |
| LOADING QUANTITY | 45pcs/20GP 104pcs/40GP 110pcs/40HQ |





HEAVY-DUTY COOK BOX



NL-BDL FEATURES

| | |
|-------------------------|--|
| COOKING AREA | 1440*955mm |
| PRODUCT SIZE | 1805*1230*1015mm |
| PACKAGE SIZE | 1530*1050*335mm; 1530*515*485mm |
| GROSS WEIGHT | 95kg |
| CHARCOAL TRAY | 720*450*80mm, Black enamel |
| BURNERS | 5.8kW infrared burners(Total 11.6kW) |
| MOTOR | 25W(220 240V,AC50/60Hz), Max Load: 60 kg |
| LOADING QUANTITY | 45pcs/20GP 104pcs/40GP 110pcs/40HQ |





NL-B6 FEATURES

| | |
|-------------------------|--|
| COOKING AREA | 1035*435mm |
| PRODUCT SIZE | 1100*560*950mm |
| PACKAGE SIZE | 1100*635*315mm |
| GROSS WEIGHT | 48kg |
| CHARCOAL TRAY | 995*300*80mm, Black enamel |
| BURNERS | 3.9kW infrared burners(Total 13.6kW) |
| MOTOR | 25W(220 240V,AC50/60Hz), Max Load: 60 kg |
| LOADING QUANTITY | 11pcs/20GP 24pcs/40GP 48pcs/40HQ |

HEAVY-DUTY AND HIGH PERFORMANCE

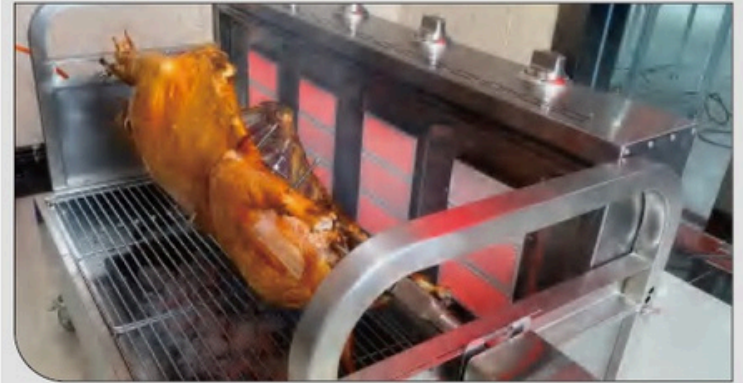

ELECTRIC MOTOR ROTISSERIE KIT



LARGE COOKING AREA





NL-B2 LIFTABLE FEATURES

| | |
|-------------------------|--|
| COOK BOX | 1172*485*255mm |
| PRODUCT SIZE | 1380*440*850mm |
| PACKAGE SIZE | 1280*475*255mm |
| GROSS WEIGHT | 38kg |
| CHARCOAL TRAY | 1020*230*80mm, Galvanized iron |
| MAX LOAD | 40kg |
| MOTOR OUTPUT | 13W(220 240V,AC50/60Hz), Max Load: 40 kg |
| LOADING QUANTITY | 180pcs/20GP 387pcs/40GP 430pcs/40HQ |

LARGE COOKING AREA



5 LEVELS LIFTABLE GRIDS



ELECTIRC MOTOR ROTISSERIE KIT





NL-B1 FEATURES

| | |
|-------------------------|--|
| COOK BOX | A:1000*560*230mm; B:1300*560*230mm |
| PRODUCT SIZE | A:1050*560*1000mm;B:1350*560*1000mm |
| PACKAGE SIZE | 1530*720*280mm |
| GROSS WEIGHT | 45kg |
| CHARCOAL TRAY | 1230*350*80mm, Galvanized iron |
| MAX LOAD | 40kg |
| MOTOR OUTPUT | 13W(220 240V,AC50/60Hz), Max Load: 40 kg |
| LOADING QUANTITY | 88pcs/20GP 184pcs/40GP 207pcs/40HQ |

FOUR LEVELS LIFTING SPIT ROD

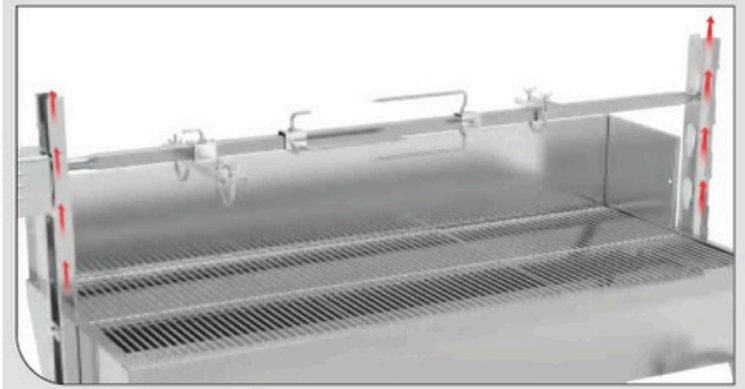

ELECTRIC MOTOR ROTISSERIE KIT



WIND SHIELD AND LARGE COOKING AREA





NL-B3 FEATURES

| | |
|----------------------------------|--|
| COOKING AREA | 1190*500mm |
| PRODUCT SIZE | 1980*620*1190mm |
| PACKAGE SIZE | 1305*660*670mm |
| GROSS WEIGHT | 87kg |
| CHARCOAL TRAY¹ | Two liftable charcoal tray |
| BURNERS | 7.8kW stainless steel burner |
| MOTOR | 25W(220 240V,AC50/60Hz), Max Load: 60 kg |
| LOADING QUANTITY | 39pcs/20GP 84pcs/40GP 108pcs/40HQ |

DOUBLE-WALLED LID



HEAVY DUTY MOTOR ROTISSERIE KIT



LARGE COOKING AREA



BEER OPENER



THERMOMETER AND TEMPERED GLASS



PIEZO IGNITION AND HEAT CONTROL

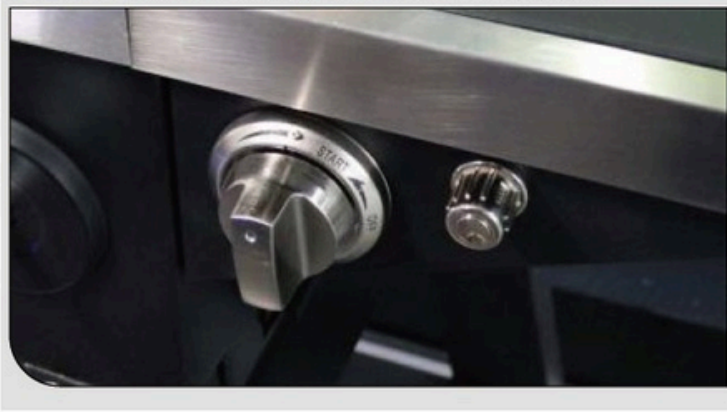

CAST ALUMINUM CONSTRUCTION



CHARCOAL TRAY LIFTING HANDLE

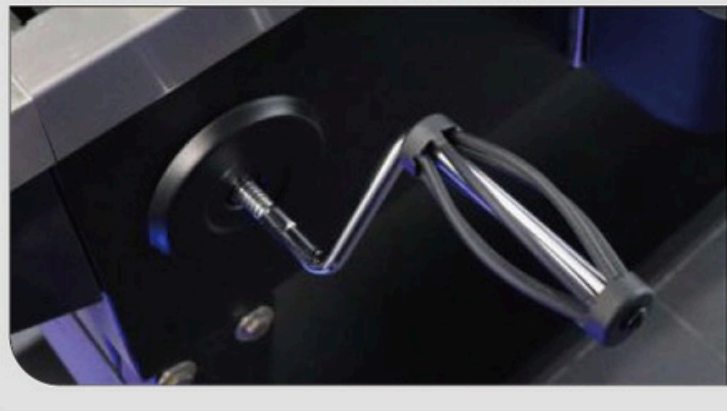

SIDE-OUT OIL DRIP TRAY

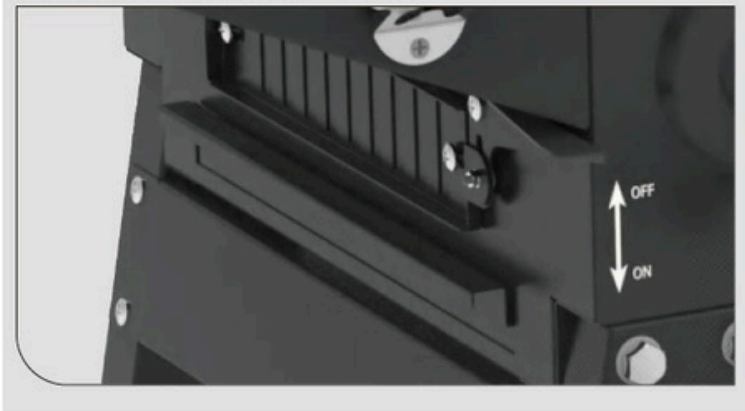



Weekend.

The Island Series

The N&L Island series combines the modern elegance of high-end interior design with the rustic appeal of a natural, outdoor environment. Offering a chic new take on the traditional backyard aesthetic, the weather-resistant dry and cold storage features stone paint, and granite countertop. With the N&L high-performance Built-in Grills, create a mouthwatering meal of flesh for your friends and family in your ultimate backyard.



NL-B4-I ISLAND FEATURES

| | |
|-------------------------|--|
| COOKING AREA | 723*460mm |
| PRODUCT SIZE | 1640*670*900mm |
| PACKAGE SIZE | 1100*635*315mm |
| GROSS WEIGHT | 190kg |
| CONSTRUCTION | Granite countertop, stone painted frame |
| PERFORMANCE | Built-in grill 19.3kW, side burner 3.5kW |
| MOTOR | 13W(220 240V,AC50/60Hz), Max Load: 40 kg |
| LOADING QUANTITY | 19pcs/20GP 40pcs/40GP 53pcs/40HQ |

CUSTOMIZABLE STONE PAINT



HIGH-PERFORMANCE BURNERS



GRANITE COUNTERTOP

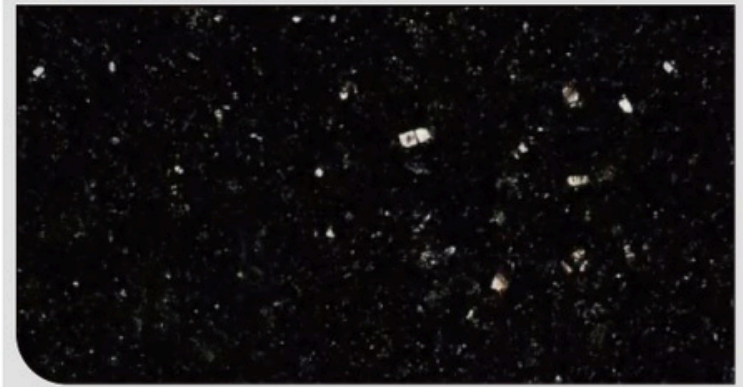



NL-B4-I-1 ISLAND FEATURES

| | |
|---------------------|--|
| COOKING AREA | 723*460mm |
| PRODUCT SIZE | 3280*670*1368mm, Countertop Height:900mm |
| GROSS WEIGHT | 380kg |
| MOTOR | 13W(220 240V,AC50/60Hz), Max Load: 40 kg |
| CONSTRUCTION | Granite countertop, stone painted frame |
| PERFORMANCE | Built-in grill 19.3kW, side burner 3.5kW |

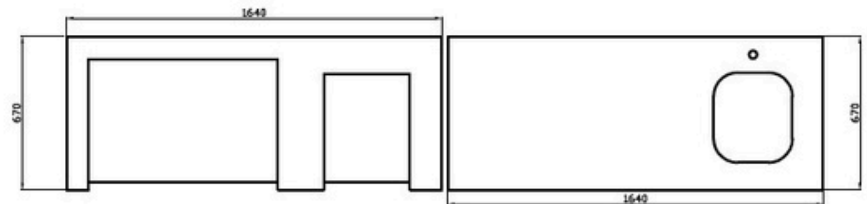

| | |
|-------------------------|---|
| REFRIGERATOR | 63L, 220-240V/50Hz,#304 Stainless steel |
| LOADING QUANTITY | 9pcs/20GP 22pcs/40GP 25pcs/40HQ |



NL-B4-I-2 ISLAND FEATURES

| | |
|---------------------|---|
| COOKING AREA | 723*460mm |
| PRODUCT SIZE | 2310*2310*1368mm, Countertop Height:900mm |
| GROSS WEIGHT | 420kg |
| MOTOR | 13W(220 240V,AC50/60Hz), Max Load: 40 kg |
| CONSTRUCTION | Granite countertop, stone painted frame |
| PERFORMANCE | Built-in grill 19.3kW, side burner 3.5kW |

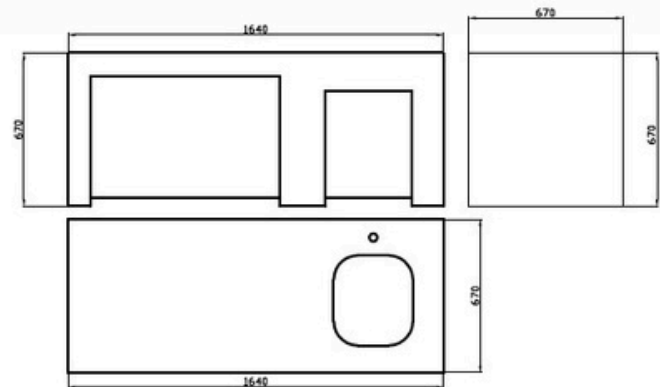

| | |
|-------------------------|---|
| REFRIGERATOR | 63L, 220-240V/50Hz,#304 Stainless steel |
| LOADING QUANTITY | 8pcs/20GP 16pcs/40GP 19pcs/40HQ |



Combination.

Outdoor kitchen Series

N&L full line of outdoor kitchen components features access door, drawers, refrigeration, sinks, cabinets and side burner. Seamless fit and elegant style that will work with any countertop and island finish.

N&L components also feature commercial grade stainless steel construction, magnetic latch, smooth gliding drawers on heavy-duty tracks. All access doors feature reversible door mounting to meet your specific needs. Sleek and intuitive, components provide an integrated solution that can be personalized to any space.



NL-CD CABINET FEATURES

| | |
|-------------------------|----------------------------------|
| PRODUCT SIZE | 830*576*900mm |
| PACKAGE SIZE | 880*670*1000mm |
| MATERIALS | Stainless steel and marble |
| GROSS WEIGHT | 64. 5kg |
| CASTER | 4 caster wheels,2 with locking |
| LOADING QUANTITY | 40pcs/20GP 86pcs/40GP 86pcs/40HQ |



NL-B10 SIDE BURNER FEATURES

| | |
|-------------------------|------------------------------------|
| PRODUCT SIZE | 487*611*900mm |
| PACKAGE SIZE | 525*640*1000mm |
| MATERIALS | Stainless steel and marble |
| GROSS WEIGHT | 38kg |
| CASTER | 4 caster wheels,2 with locking |
| BURNER | 3.9kW infrared burner |
| LOADING QUANTITY | 76pcs/20GP 154pcs/40GP 154pcs/40HQ |



NL-CF1 CABINET FEATURES

| | |
|-------------------------|---|
| PRODUCT SIZE | 963*603*900mm |
| PACKAGE SIZE | 1010*665*1000mm |
| MATERIALS | Stainless steel and marble |
| GROSS WEIGHT | 97kg |
| CASTER | 4 caster wheels,2 with locking |
| REFRIGERATOR | 63L, 220-240V/50Hz,#304 Stainless steel |
| LOADING QUANTITY | 34pcs/20GP 72pcs/40GP 72pcs/40HQ |



NL-CF2 CABINET FEATURES

| | |
|-------------------------|---|
| PRODUCT SIZE | 963*603*900mm |
| PACKAGE SIZE | 1010*665*1000mm |
| MATERIALS | Stainless steel and marble |
| GROSS WEIGHT | 125kg |
| CASTER | 4 caster wheels,2 with locking |
| REFRIGERATOR | 63L, 220-240V/50Hz,#304 Stainless steel |
| LOADING QUANTITY | 34pcs/20GP 72pcs/40GP 72pcs/40HQ |



NL-CDSF CABINET FEATURES

| | |
|-------------------------|---|
| PRODUCT SIZE | 963*603*1371mm |
| PACKAGE SIZE | 1010*665*1000mm |
| MATERIALS | Stainless steel and marble |
| GROSS WEIGHT | 96kg |
| CASTER | 4 caster wheels,2 with locking |
| REFRIGERATOR | 63L, 220-240V/50Hz,#304 Stainless steel |
| LOADING QUANTITY | 34pcs/20GP 72pcs/40GP 72pcs/40HQ |



NL-CDS CABINET FEATURES

| | |
|-------------------------|----------------------------------|
| PRODUCT SIZE | 830*576*1371mm |
| PACKAGE SIZE | 880*670*1000mm |
| MATERIALS | Stainless steel and marble |
| GROSS WEIGHT | 63kg |
| CASTER | 4 caster wheels,2 with locking |
| LOADING QUANTITY | 40pcs/20GP 86pcs/40GP 86pcs/40HQ |



NL-CC45 45° CORNER FEATURES

| | |
|-------------------------|-------------------------------------|
| PRODUCT SIZE | 528*533*900mm |
| PACKAGE SIZE | 530*190*900mm |
| MATERIALS | Stainless steel and marble |
| GROSS WEIGHT | 18.3kg |
| CASTER | 3 caster wheels |
| LOADING QUANTITY | 340pcs/20GP 706pcs/40GP 791pcs/40HQ |



NL-CC9 90° CORNER FEATURES

| | |
|-------------------------|-------------------------------------|
| PRODUCT SIZE | 626*626*900mm |
| PACKAGE SIZE | 670*150*670mm, 560*10*750mm |
| MATERIALS | Stainless steel and marble |
| GROSS WEIGHT | 44kg |
| CASTER | 4 caster wheels, 2 with locking |
| LOADING QUANTITY | 271pcs/20GP 564pcs/40GP 620pcs/40HQ |



NL-CC9-I 90° CORNER FEATURES

| | |
|-------------------------|--|
| PRODUCT SIZE | 650*650*900mm |
| PACKAGE SIZE | 960*710*830mm |
| CONSTRUCTION | Stone paint body and marble countertop |
| GROSS WEIGHT | 70kg |
| FEET | Four adjustable rubber feet |
| LOADING QUANTITY | 340pcs/20GP 706pcs/40GP 791pcs/40HQ |



NL-CC9-I 90° CORNER FEATURES

| | |
|-------------------------|--|
| PRODUCT SIZE | 650*650*900mm |
| PACKAGE SIZE | 960*710*830mm |
| CONSTRUCTION | Stone paint body and marble countertop |
| GROSS WEIGHT | 70kg |
| FEET | Four adjustable rubber feet |
| LOADING QUANTITY | 271pcs/20GP 564pcs/40GP 620pcs/40HQ |

Combination.

SHOW CASE

N&L full line of outdoor kitchen components features access door, drawers, refrigeration, sinks, cabinets and side burner. Seamless fit and elegant style that will work with any countertop and island finish. N&L components also feature commercial grade stainless steel construction, magnetic latch, smooth gliding drawers on heavy-duty tracks. All access doors feature reversible door mounting to meet your specific needs. Sleek and intuitive, components provide an integrated solution that can be personalized to any space.





NL-B9 FEATURES

| | |
|-------------------------|--|
| COOKING AREA | 960*455mm |
| PRODUCT SIZE | 3140*600*1240mm, Countertop Height:900mm |
| GROSS WEIGHT | 256kg |
| CONSTRUCTION | Stainless steel and marble |
| MOTOR | 13W(220 240V,AC50/60Hz), Max Load: 40 kg |
| PERFORMANCE | Built-in grill 26.7kW, side burner 3.9kW |
| LOADING QUANTITY | 7pcs/20GP 15pcs/40GP 16pcs/40HQ |



COMBINE WITH NL-B8



NL-B801-2-1 FEATURES

| | |
|---------------------|--|
| COOKING AREA | 960*455mm |
| PRODUCT SIZE | 2551*633*1197mm, Countertop Height:900mm |
| GROSS WEIGHT | 261kg |
| MOTOR | 13W(220 240V,AC50/60Hz), Max Load: 40 kg |
| CONSTRUCTION | Stainless steel and marble |
| PERFORMANCE | Built-in grill 26.7kW, side burner 3.9kW |

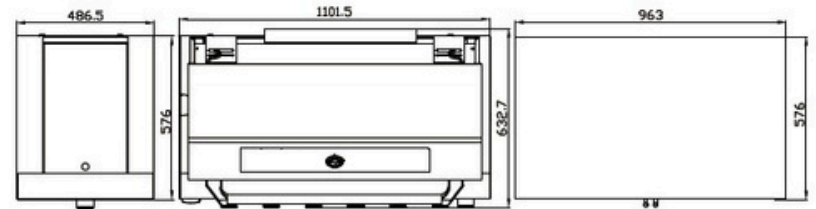

| | |
|-------------------------|---|
| REFRIGERATOR | 63L, 220-240V/50Hz,#304 Stainless steel |
| LOADING QUANTITY | 13pcs/20GP 24pcs/40GP 28pcs/40HQ |



NL-B801-2-1-S FEATURES

| | |
|---------------------|--|
| COOKING AREA | 960*455mm |
| PRODUCT SIZE | 2551*633*1197mm, Countertop Height:900mm |
| GROSS WEIGHT | 261kg |
| MOTOR | 13W(220 240V,AC50/60Hz), Max Load: 40 kg |
| CONSTRUCTION | Stainless steel and marble |
| PERFORMANCE | Built-in grill 26.7kW, side burner 3.9kW |

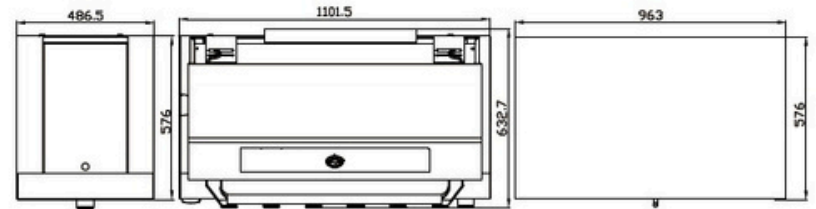

| | |
|-------------------------|---|
| REFRIGERATOR | 63L, 220-240V/50Hz,#304 Stainless steel |
| LOADING QUANTITY | 13pcs/20GP 24pcs/40GP 28pcs/40HQ |



NL-B801-2-2 FEATURES

| | |
|---------------------|--|
| COOKING AREA | 960*455mm |
| PRODUCT SIZE | 2551*633*1370mm, Countertop Height:900mm |
| GROSS WEIGHT | 286kg |
| MOTOR | 13W(220 240V,AC50/60Hz), Max Load: 40 kg |
| CONSTRUCTION | Stainless steel and marble |
| PERFORMANCE | Built-in grill 26.7kW |

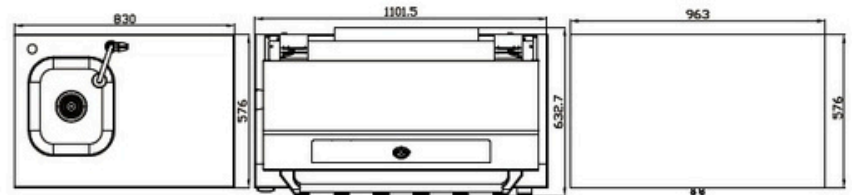

| | |
|-------------------------|---|
| REFRIGERATOR | 63L, 220-240V/50Hz,#304 Stainless steel |
| LOADING QUANTITY | 9pcs/20GP 21pcs/40GP 24pcs/40HQ |



NL-B801-2-2-S FEATURES

| | |
|---------------------|--|
| COOKING AREA | 960*455mm |
| PRODUCT SIZE | 2551*633*1370mm, Countertop Height:900mm |
| GROSS WEIGHT | 286kg |
| MOTOR | 13W(220 240V,AC50/60Hz), Max Load: 40 kg |
| CONSTRUCTION | Stainless steel and marble |
| PERFORMANCE | Built-in grill 26.7kW |

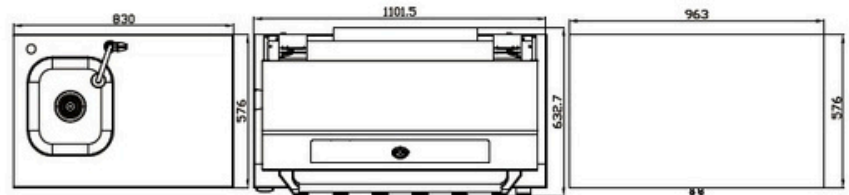

| | |
|-------------------------|---|
| REFRIGERATOR | 63L, 220-240V/50Hz,#304 Stainless steel |
| LOADING QUANTITY | 9pcs/20GP 21pcs/40GP 24pcs/40HQ |



NL-B801-2-3 FEATURES

| | |
|---------------------|--|
| COOKING AREA | 960*455mm |
| PRODUCT SIZE | 2895*633*1197mm, Countertop Height:900mm |
| GROSS WEIGHT | 261kg |
| MOTOR | 13W(220 240V,AC50/60Hz), Max Load: 40 kg |
| CONSTRUCTION | Stainless steel and marble |
| PERFORMANCE | Built-in grill 26.7kW, side burner 3.9kW |

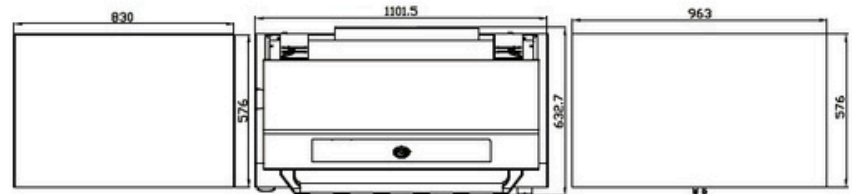

| | |
|-------------------------|---|
| REFRIGERATOR | 63L, 220-240V/50Hz,#304 Stainless steel |
| LOADING QUANTITY | 9pcs/20GP 21pcs/40GP 24pcs/40HQ |



NL-B801-2-3-S FEATURES

| | |
|---------------------|--|
| COOKING AREA | 960*455mm |
| PRODUCT SIZE | 2895*633*1197mm, Countertop Height:900mm |
| GROSS WEIGHT | 261kg |
| MOTOR | 13W(220 240V,AC50/60Hz), Max Load: 40 kg |
| CONSTRUCTION | Stainless steel and marble |
| PERFORMANCE | Built-in grill 26.7kW, side burner 3.9kW |

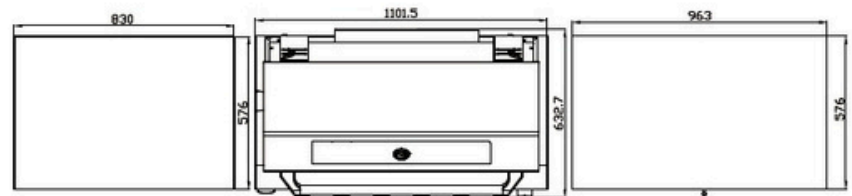

| | |
|-------------------------|---|
| REFRIGERATOR | 63L, 220-240V/50Hz,#304 Stainless steel |
| LOADING QUANTITY | 9pcs/20GP 21pcs/40GP 24pcs/40HQ |



NL-B801-3 FEATURES

| | |
|---------------------|--|
| COOKING AREA | 960*455mm |
| PRODUCT SIZE | 3381*633*1197mm, Countertop Height:900mm |
| GROSS WEIGHT | 324kg |
| MOTOR | 13W(220 240V,AC50/60Hz), Max Load: 40 kg |
| CONSTRUCTION | Stainless steel and marble |
| PERFORMANCE | Built-in grill 26.7kW, side burner 3.9kW |

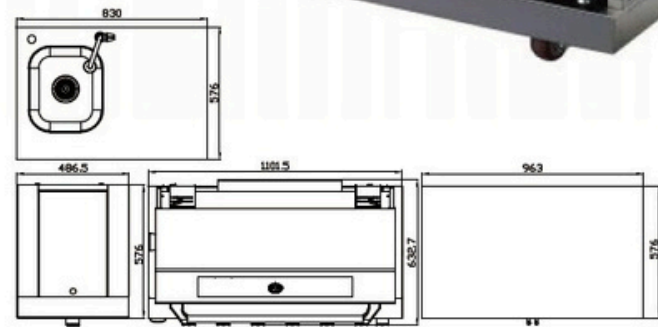

| | |
|-------------------------|---|
| REFRIGERATOR | 63L, 220-240V/50Hz,#304 Stainless steel |
| LOADING QUANTITY | 9pcs/20GP 17pcs/40GP 21pcs/40HQ |



NL-B801-3-S FEATURES

| | |
|---------------------|--|
| COOKING AREA | 960*455mm |
| PRODUCT SIZE | 3381*633*1197mm, Countertop Height:900mm |
| GROSS WEIGHT | 324kg |
| MOTOR | 13W(220 240V,AC50/60Hz), Max Load: 40 kg |
| CONSTRUCTION | Stainless steel and marble |
| PERFORMANCE | Built-in grill 26.7kW, side burner 3.9kW |

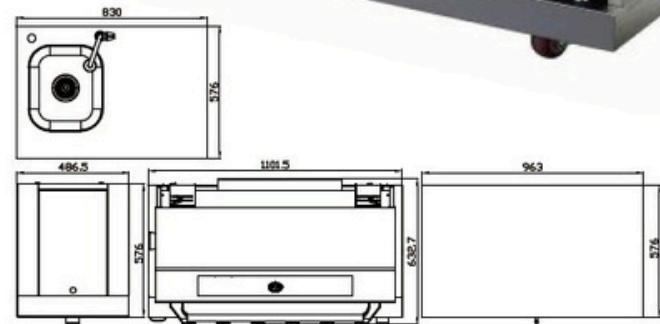

| | |
|-------------------------|---|
| REFRIGERATOR | 63L, 220-240V/50Hz,#304 Stainless steel |
| LOADING QUANTITY | 9pcs/20GP 17pcs/40GP 21pcs/40HQ |



NL-B801-4 FEATURES

| | |
|---------------------|---|
| COOKING AREA | 960*455mm |
| PRODUCT SIZE | 3521*1456*1370mm, Countertop Height:900mm |
| GROSS WEIGHT | 387kg |
| MOTOR | 13W(220 240V,AC50/60Hz), Max Load: 40 kg |
| CONSTRUCTION | Stainless steel and marble |
| PERFORMANCE | Built-in grill 26.7kW |

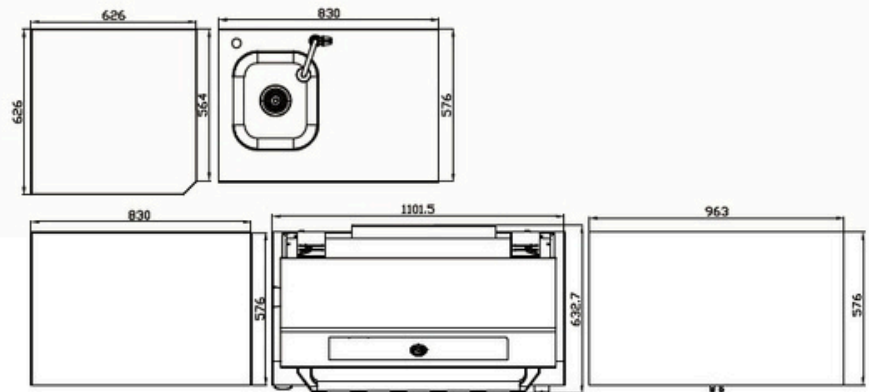

| | |
|-------------------------|---|
| REFRIGERATOR | 63L, 220-240V/50Hz,#304 Stainless steel |
| LOADING QUANTITY | 7pcs/20GP 17pcs/40GP 20pcs/40HQ |



NL-B801-4-S FEATURES

| | |
|---------------------|---|
| COOKING AREA | 960*455mm |
| PRODUCT SIZE | 3521*1456*1370mm, Countertop Height:900mm |
| GROSS WEIGHT | 387kg |
| MOTOR | 13W(220 240V,AC50/60Hz), Max Load: 40 kg |
| CONSTRUCTION | Stainless steel and marble |
| PERFORMANCE | Built-in grill 26.7kW |

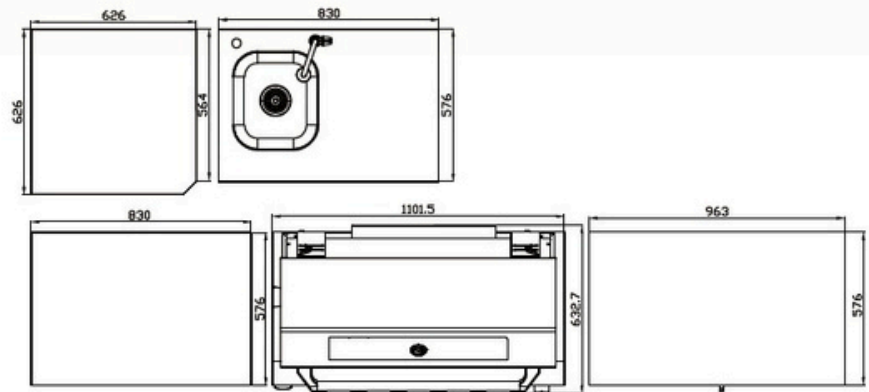

| | |
|-------------------------|--|
| REFRIGERATOR | 63L, 220-240V/50Hz, #304 Stainless steel |
| LOADING QUANTITY | 7pcs/20GP 17pcs/40GP 20pcs/40HQ |



NL-B801-5-1 FEATURES

| | |
|---------------------|---|
| COOKING AREA | 960*455mm |
| PRODUCT SIZE | 4008*1456*1370mm, Countertop Height:900mm |
| GROSS WEIGHT | 425kg |
| MOTOR | 13W(220 240V,AC50/60Hz), Max Load: 40 kg |
| CONSTRUCTION | Stainless steel and marble |
| PERFORMANCE | Built-in grill 26.7kW, side burner 3.9kW |

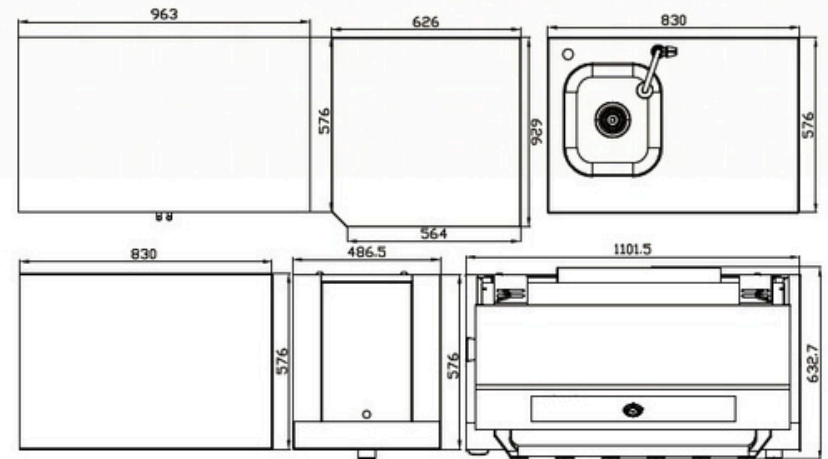

| | |
|-------------------------|---|
| REFRIGERATOR | 63L, 220-240V/50Hz,#304 Stainless steel |
| LOADING QUANTITY | 7pcs/20GP 15pcs/40GP 16pcs/40HQ |



NL-B801-5-1-S FEATURES

| | |
|---------------------|---|
| COOKING AREA | 960*455mm |
| PRODUCT SIZE | 4008*1456*1370mm, Countertop Height:900mm |
| GROSS WEIGHT | 425kg |
| MOTOR | 13W(220 240V,AC50/60Hz), Max Load: 40 kg |
| CONSTRUCTION | Stainless steel and marble |
| PERFORMANCE | Built-in grill 26.7kW, side burner 3.9kW |

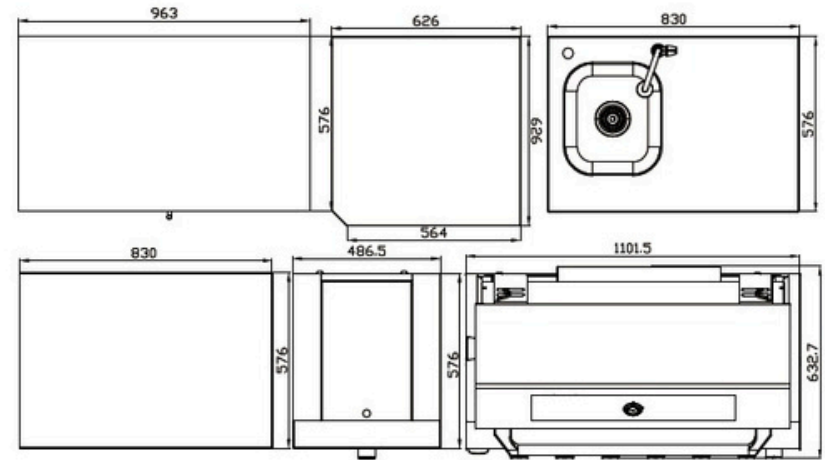

| | |
|-------------------------|---|
| REFRIGERATOR | 63L, 220-240V/50Hz,#304 Stainless steel |
| LOADING QUANTITY | 7pcs/20GP 15pcs/40GP 16pcs/40HQ |



NL-B801-5-2 FEATURES

| | |
|---------------------|---|
| COOKING AREA | 960*455mm |
| PRODUCT SIZE | 3176*2286*1370mm, Countertop Height:900mm |
| GROSS WEIGHT | 387kg |
| MOTOR | 13W(220 240V,AC50/60Hz), Max Load: 40 kg |
| CONSTRUCTION | Stainless steel and marble |
| PERFORMANCE | Built-in grill 26.7kW, side burner 3.9kW |

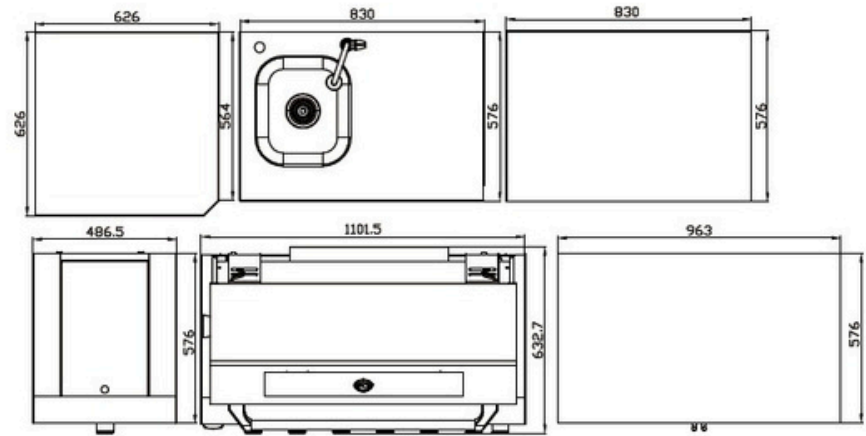

| | |
|-------------------------|--|
| REFRIGERATOR | 63L, 220-240V/50Hz, #304 Stainless steel |
| LOADING QUANTITY | 7pcs/20GP 15pcs/40GP 16pcs/40HQ |



NL-B801-5-2-S FEATURES

| | |
|---------------------|---|
| COOKING AREA | 960*455mm |
| PRODUCT SIZE | 3176*2286*1370mm, Countertop Height:900mm |
| GROSS WEIGHT | 387kg |
| MOTOR | 13W(220 240V,AC50/60Hz), Max Load: 40 kg |
| CONSTRUCTION | Stainless steel and marble |
| PERFORMANCE | Built-in grill 26.7kW, side burner 3.9kW |

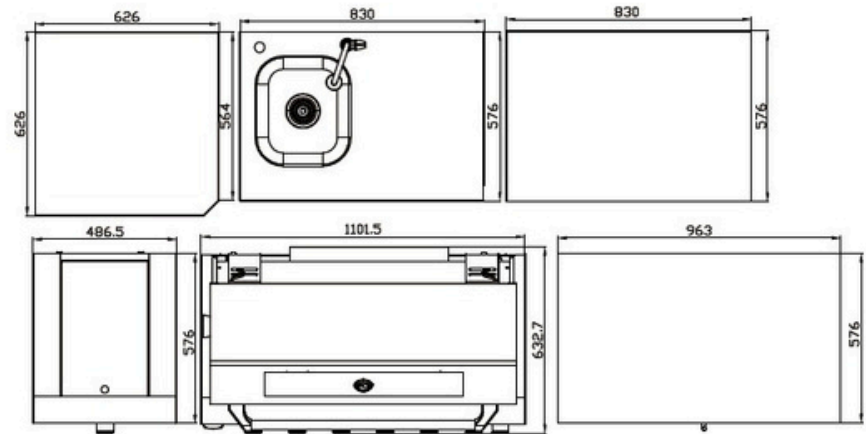

| | |
|-------------------------|--|
| REFRIGERATOR | 63L, 220-240V/50Hz, #304 Stainless steel |
| LOADING QUANTITY | 7pcs/20GP 15pcs/40GP 16pcs/40HQ |



800°.

Steak & Pizza Maker Series

The N&L 800° Steak Grill let you experience steakhouse style grilling in your own backyard! Its unique and efficient rectangular, front-loading open design accommodates OverFire radiant burners which are housed in the top of the grill. It is these OverFire radiant burners that allow the grill to get to 800°, a temperature they can achieve in just three minutes. This more direct heating allows for higher steak-searing temperatures, faster cooking and it takes the food-drying air out of the equation, all reasons high-end steakhouses use this technology.

COOLING HOLE



800° HIGH-PERFORMANCE



NONSKID KNOB AND PULSE IGNITION

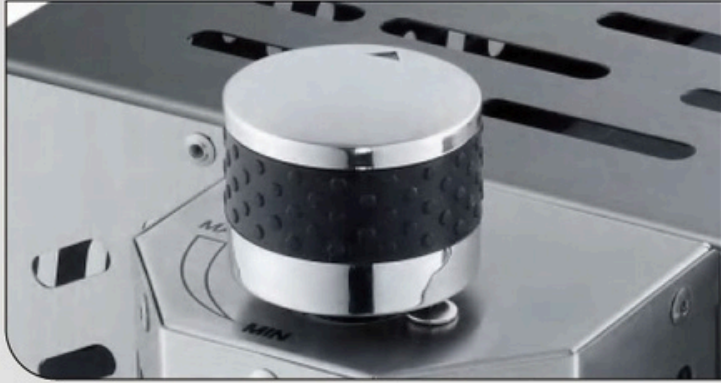

FRONT-LOADING AND 5 GEAR GRILL



USE-FRIENDLY COUNTERTOP



MULTIFUNCTIONAL GRILL

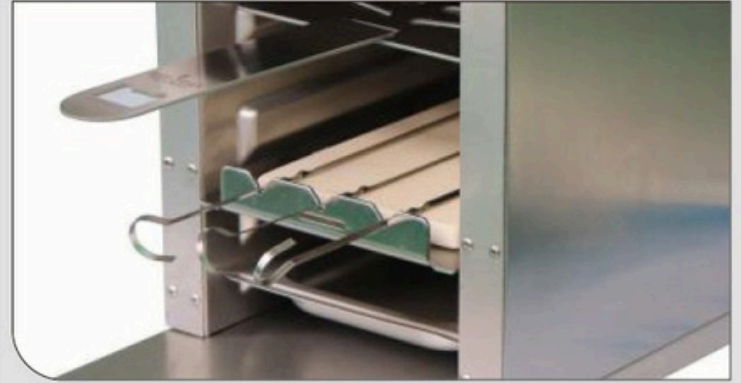

STEAK GRILL SERIES FEATURES

| | |
|----------------------|--------------------------------|
| COOKING GRIDS | #304/430 stainless steel grids |
| HEAT CONTROL | Valves with 90° control |
| BURNER | Infrared burner |
| IGNITOR | Pulse ignitor |
| DRIP TRAY | Oil drip tray available |
| HANDLE | Grid handle with beer opener |
| POWER SOURCE | LNG, LPG, BUTANE |



NL-HS100A-1 FEATURES

| | |
|-------------------------|--------------------------------------|
| COOKING AREA | 265*165mm |
| PRODUCT SIZE | 540*220*410mm |
| PACKAGE SIZE | 560*260*440mm |
| MATERIALS | #304 stainless steel |
| GROSS WEIGHT | 9.5kg |
| PERFORMANCE | 12000BTU/3.5kW |
| IGNITION | Pulse ignition |
| LOADING QUANTITY | 480pcs/20GP 990pcs/40GP 1180pcs/40HQ |



STANDARD COMPONENTS

STEAK GRID



GRID HANDLE



OIL DRIP PAN



OPTIONAL COMPONENTS

BBQ SKEWERS



PIZZA STONE SET



REGULATOR AND
GAS HOSE



WATERPROOF GIRLL COVER





NL-HS100A-2 FEATURES

| | |
|-------------------------|--------------------------------------|
| COOKING AREA | 265*165mm |
| PRODUCT SIZE | 540*220*410mm |
| PACKAGE SIZE | 560*260*440mm |
| MATERIALS | #304 stainless steel |
| GROSS WEIGHT | 9.5kg |
| PERFORMANCE | 12000BTU/3.5kW |
| IGNITION | Pulse ignition |
| LOADING QUANTITY | 480pcs/20GP 990pcs/40GP 1180pcs/40HQ |



NL-HS100A-3 FEATURES

| | |
|-------------------------|--------------------------------------|
| COOKING AREA | 265*165mm |
| PRODUCT SIZE | 540*220*410mm |
| PACKAGE SIZE | 560*260*440mm |
| MATERIALS | #304 stainless steel |
| GROSS WEIGHT | 9.5kg |
| PERFORMANCE | 12000BTU/3.5kW |
| IGNITION | Pulse ignition |
| LOADING QUANTITY | 480pcs/20GP 990pcs/40GP 1180pcs/40HQ |



NL-P100 FEATURES

| | |
|-------------------------|-------------------------------------|
| COOKING AREA | 330*340mm |
| PRODUCT SIZE | 560*445*560mm |
| PACKAGE SIZE | 570*475*435mm |
| MATERIALS | Stainless steel |
| GROSS WEIGHT | kg |
| PERFORMANCE | 13000BTU/3.8kW |
| IGNITION | Piezo ignition |
| LOADING QUANTITY | 225pcs/20GP 470pcs/40GP 564pcs/40HQ |



NL-HS100A-2 FEATURES

| | |
|-------------------------|-------------------------------------|
| COOKING AREA | 310*360mm |
| PRODUCT SIZE | 540*430*450mm |
| PACKAGE SIZE | 510*575*480mm |
| MATERIALS | Stainless steel |
| GROSS WEIGHT | 19.5kg |
| PERFORMANCE | 11260BTU/3.3kW |
| IGNITION | Pulse ignition |
| LOADING QUANTITY | 176pcs/20GP 368pcs/40GP 460pcs/40HQ |



NL-HS100A-1 FEATURES

| | |
|-------------------------|-------------------------------------|
| COOKING AREA | 330*250mm |
| PRODUCT SIZE | 450*350*430mm |
| PACKAGE SIZE | 490*370*440mm |
| MATERIALS | Stainless steel |
| GROSS WEIGHT | 14kg |
| PERFORMANCE | 12000BTU/3.5kW |
| TIMER KNOB | 15 minutes timer knob |
| LOADING QUANTITY | 375pcs/20GP 770pcs/40GP 912pcs/40HQ |



NL-HS200B FEATURES

| | |
|-------------------------|-------------------------------------|
| COOKING AREA | 330*340mm |
| PRODUCT SIZE | 540*430*490mm |
| PACKAGE SIZE | 580*480*510mm |
| MATERIALS | Stainless steel |
| GROSS WEIGHT | 23kg |
| PERFORMANCE | 30000BTU/8. 2kW |
| IGNITION | Piezo ignition |
| LOADING QUANTITY | 190pcs/20GP 380pcs/40GP 480pcs/40HQ |

800° HIGH-PERFORMANCE

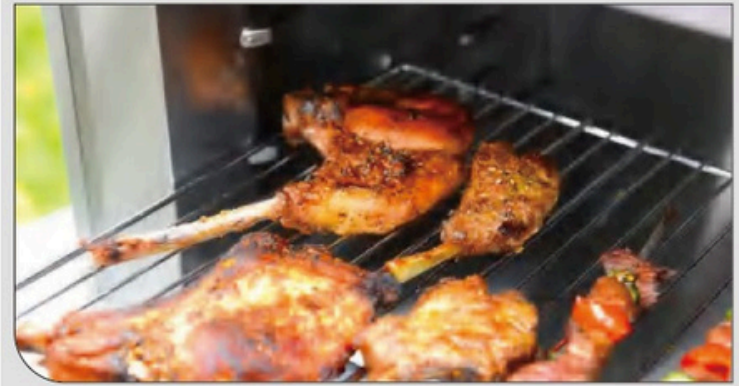

FRONT-LOADING AND 5 GEAR GRILL



LARGER GRID FOR FAMILY

